

# User Manual For Clamp H-Beam 80-180

This user manual is to be kept through the complete user period for the tool

Original User Manual

Ref. NORSOK R-002

Product: **Clamp H-Beam 80-180**

Model number: **WT-80-180**

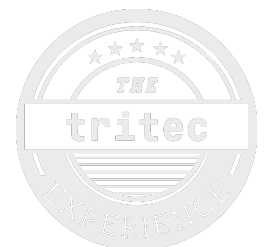
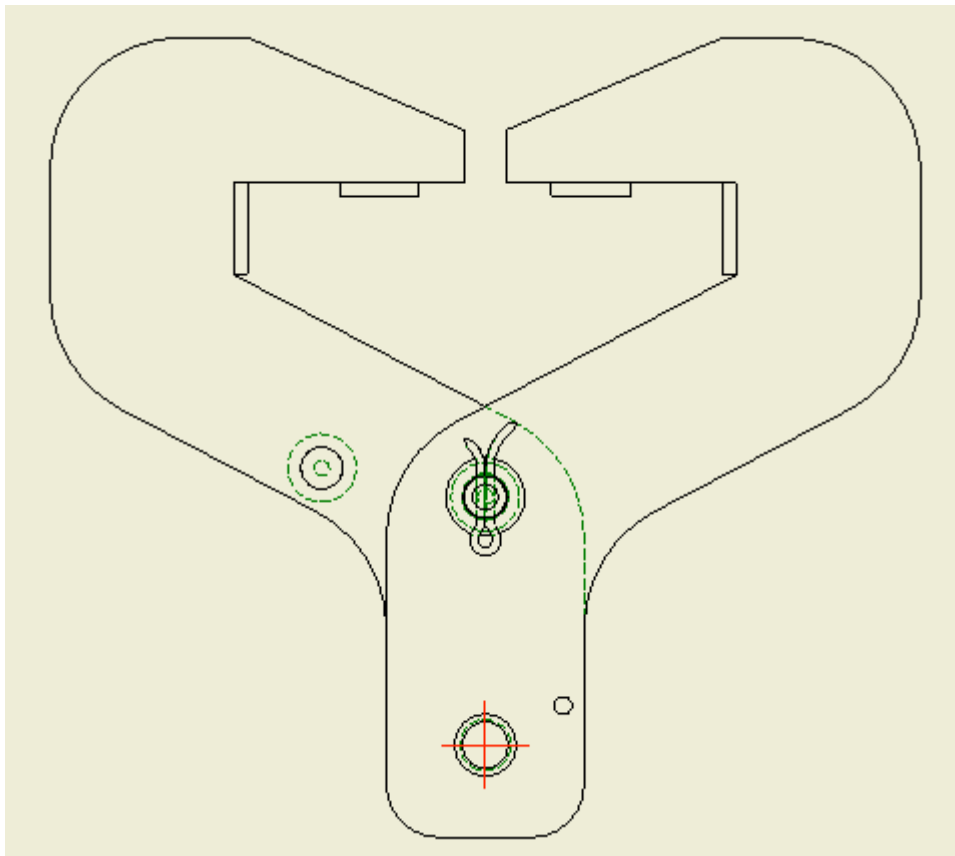

**This User Manual do not replace the user training of the operator for use.**

Rev. 0

## Content

	Page
<b>1. MACHINE DESCRIPTION</b>	
1.1 PRODUCT DATA	3
1.2 EQUIPMENT DESCRIPTION	4
1.3 GENERAL INFORMATION	5
<b>2. SAFETY INSTRUCTIONS</b>	6
2.1 EXPLANATION OF WARNING SIGNS	6
2.2 GENERAL SAFETY INSTRUCTIONS FOR REGULATORY USE	7
<b>3. STARTUP</b>	8
3.1 ASSEMBLING AND DISASSEMBLING CONDITIONS	8
3.2 SECURING LOAD OF CLAMP H-BEAM 80-180	8
3.3 TRANSPORT LOAD OF CLAMP H-BEAM 80-180	9
3.4 PUT DOWN LOAD OF CLAMP H-BEAM 80-180	10
<b>4. CONTROL, MAINTENANCE AND REPAIR</b>	10
4.1 INSPECTION BEFORE FIRST TIME USE	10
4.2 REGULAR INSPECTIONS	10
4.3 EXTRAORDINARY INSPECTION	11
<b>5. USE</b>	11

## 1. MACHINE DESCRIPTION

### 1.1 PRODUCT DATA

Producer:	Tritec Engineering AS Hetlandsgata 9 4344 Bryne Tlf +47 40 40 44 44 <a href="mailto:post@tritec.no">post@tritec.no</a>
Designation:	Clamp H-Beam 80-180
Type:	WT-80-180
Standard:	NORSOK R-002
Drawing no.:	WT-80-180
Year of manufacture:	2014
Load Capacity:	20 kN
Weight:	4,8 KG
Declaration Of Conformity:	Defined by EU Machinery Directive 2006/42/EU
Copyright:	Tritec Engineering AS

Any use, copying or duplication of these documents, is only permitted by written approval from Tritec Engineering AS.

Any misuse is illegal and can lead to lawsuit.

## 1.2 EQUIPMENT DESCRIPTION

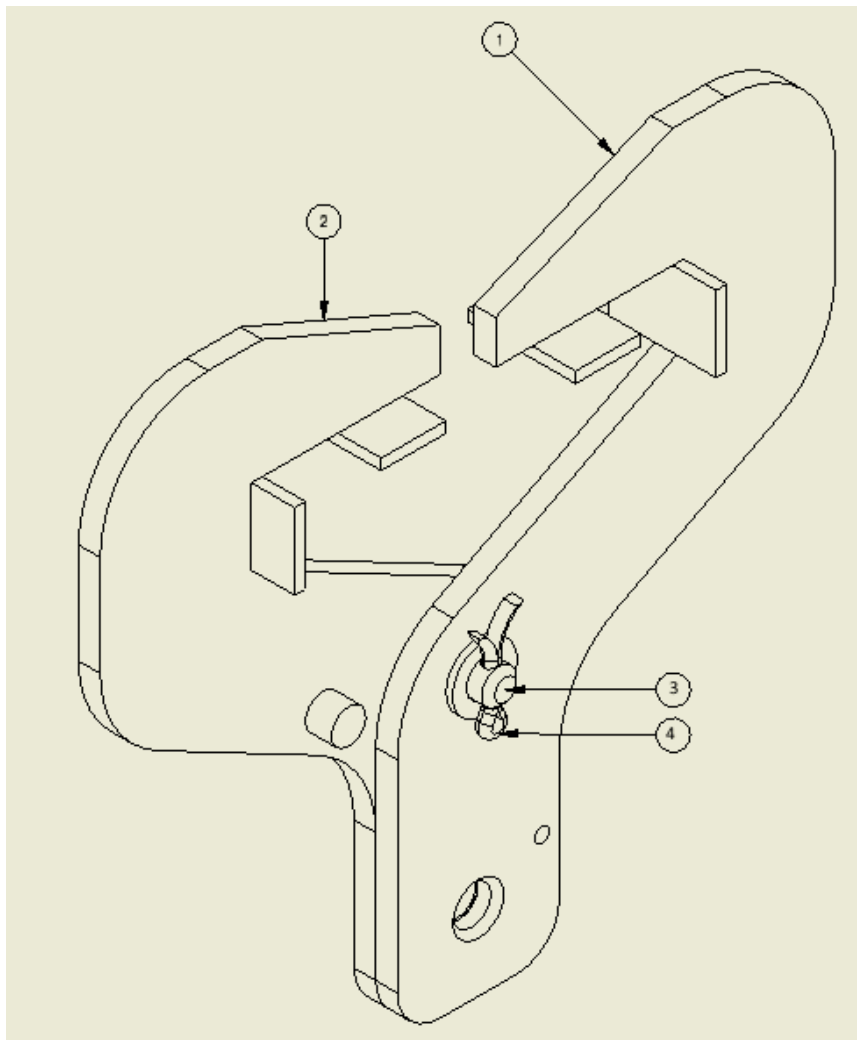

**DWG. 1 Clamp H-Beam 80-180 – assembly drawing**

Clamp H-Beam 80-180 designed for H-beam with flange width 80-180 mm, flange thickness max. 35 mm and thickness of web max 16 mm.

Permissible load 20 kN.

Surface is prepared with standard NORSOK M-501 system no.6.

Surface coating: Hot Dip Galvanised

Clamp H-Beam 80-180 is fabricated in material S355J2. Minimum yield is 355 MPa.

Clamp H-Beam 80-180 is assembly (pos. 1 and 2) on a bolt (pos. 3) and secured with a clamp (pos. 4).

### 1.3 GENERAL INFORMATION

- This document describes the Clamp H-Beam 80-180 and how to use it.  
In case of something indistinct, please contact Tritec Engineering AS
- It is of high importance that this document is read and understood by the operator before use.
- This document is addressed to qualified personnel for operation, inspection, maintenance and repair of the equipment. The lifting accessory is to be operated, inspected, maintained and repaired by adequate qualified personnel.
- This document make use SI standard.
- All inspection, maintenance standards, and deadlines described herein, is to be followed and documented by the operator.
- The Clamp H-Beam 80-180 must be used for its intended purpose only, meaning: do not exceed SWL:20 kN  
Other use is not permitted, and release Tritec Engineering AS from any guaranty and responsibility.
- This document is to be kept available at all times during equipment lifetime.
- Copyright for this document remains with Tritec Engineering AS.  
This document, nor any part of it, must be made available for Tritec Engineering's competitors.
- Tritec Engineering AS makes reservation for eventual change in this document.  
All data and information in this document, is given to the best of our knowledge about the equipment and the handling/operation of it.  
Tritec Engineering AS accept no responsibility or liability from the use of information herein.

## 2. SAFETY INSTRUCTIONS

Safety regulations recall standard: Safe use of lifting equipment NORSOK STANDARD R-003

### 2.1 EXPLANATION OF WARNING SIGNS



Any marketing, startup, use, inspection, maintenance and repair of this lifting beam, can only be done on the basis of the instructions and procedures given in this document.

Carefully read through this document before any use of the Clamp H-Beam 80-180.

Important instructions, especially technical safety instructions is marked with matching symbols of significance as described below.

Instructions must be followed to avoid danger for both humans and equipment.



Imminent danger - death or serious injury occurs.



Possible impending danger – death or serious injury can occur.



Possible impending danger – less serious injuries or property damage may occur.



Possible impending danger due to suspended load – death or serious injury can occur.



Possible impending danger due to suspended load – death or serious injury can occur.



Directions in relation to protection of property.

## 2.2 GENERAL SAFETY INSTRUCTIONS FOR REGULATORY USE

- Use the Clamp H-Beam 80-180 according to specifications
- The Clamp H-Beam 80-180 should be used only by personnel proper trained in accordance to regulations.
- For safe use the lifting beam must as a minimum be marked:
  - Classification by producer/vendor
  - Lifting Capacity
  - Weight
  - Equipment Identifications Number (serial number/Model number)
  - Certification Tag
  - Year Of Construction
  - CE Mark
- Before startup, the Clamp H-Beam 80-180 is subjected to a thorough visual inspection to discover any damage.
- Clamp H-Beam 80-180 without proper or unreadable marking, shall not be used.
- It is not allowed to use the Clamp H-Beam 80-180 out of its temperature range: -20° till +80° Celsius, nor under chemical influence by acids, salt or in explosive surroundings.
- It is not allowed to lift or transport any load above a person.
- Always use appropriate dope and certified lifting equipment.
- Always use updated user manuals.

### 3. STARTUP

#### 3.1 ASSEMBLING AND DISASSEMBLING CONDITIONS



**Risk of damage to the Clamp H-Beam 80-180**

The Clamp H-Beam 80-180 has to be protected against influence due to weather conditions or aggressive media.  
Stored in a suitable place.



**Stable and secure storage of the Clamp H-Beam 80-180**

The Clamp H-Beam 80-180 need to be proper handled, placed and secured in such a way it can't slide, tilt, or fall down.  
Use appropriate storage facilities.

#### 3.2 SECURING LOAD OF Clamp H-Beam 80-180

- The Clamp H-Beam 80-180 must be removed from the packaging or transport pallet.
- Perform extraordinary inspection prior to use.



**Hazard due to unsecured Clamp H-Beam 80-180, respectively not secured components.**

Load can get loose and fall down if the load attachment is not proper secured.  
Make sure that Clamp H-Beam 80-180, components and cargo is properly secured.



**Hazard due to unsecured components of the hoist.**

Do not use equipment with loose or unsecured components.  
Always check for any loose components prior to use.  
Make sure the Clamp H-Beam 80-180 is adequately secured, respectively connection locked.



**Hazard due to overload.**

The load weight must not exceed the Clamp H-Beam 80-180 specified capacity.  
If so, the hoist can be deformed and fall down.



Prior to every use, make sure that the summary of loads do not overcome the maximum load rating.



**Hazard due to clamping and locking.**

During pick-up – loading – unloading a risk of crushing and damage may occur to hands and feet between following contact points:

- The load and the place where it is put down.
- Contact point between the load and the Clamp H-Beam 80-180.
- Contact point between the Clamp H-Beam 80-180 and the hoist.

Check that the operator avoid all places with danger of crushing.



**Hazard due to oblique and shock lifted load.**

In case of jerkily and oblique lifting, overload can occur on the Clamp H-Beam 80-180. This can cause harm to the equipment.

Ensure to lift and handle any load in a proper way.

### 3.3 TRANSPORT LOAD OF Clamp H-Beam 80-180



**Hazard due to limited space.**

During transport make sure there is enough space to any surrounding obstacles to avoid collisions.

Ensure enough space in the working area.



**Hazard of dropped load due to material defects, collisions or negligence.**

If dropping or oscillating load systems, personnel staying or moving close to the hanging load, incur serious injuries or fatality.

Never stand or move under suspended load.



**Hazard due to crushing.**

Under transport of lifting beam, crushing of fingers and feet can occur.

Use appropriate and certified lifting equipment.



**Hazard due to damages and defects**

Look for damage or defects on the lifting accessory before and during operation. This may be deformation, fractures etc.

Monitor the lifting equipment during operation.

### 3.4 PUT DOWN LOAD OF Clamp H-Beam 80-180



**Hazard due to sliding or tilting when unloading on oblique surface.**

When unloading on an oblique surface, the load may slide or tilt.

Ensure adequate surface on the place for unloading.

Make sure the load don't tilt or slide when unloading, and that the place is adequate and prepared.



**Hazard due to space limitation.**

Prepare the destination before unloading.

Ensure adequate workspace relative to surrounding obstacles, to avoid hazard due to collision and crushing.

Ensure proper workspace and that the load will be put down in a careful and safe manner.

## 4. CONTROL, MAINTENANCE AND REPAIR

Country regulations, determine type, scope and deadlines concerning required inspection of the lift accessory. First time inspection before use, is additional to Extraordinary Control Of Competence. This is normally a visual control with additional function test.

### 4.1 INSPECTION BEFORE FIRST TIME USE

Before first time use, the lifting accessory must be inspected by an *Enterprise Of Competence*, and can't be used before its certified for use.

The inspection has to be documented in the certificate (control book).

### 4.2 REGULAR INSPECTIONS

- All lifting equipment has to be certified acc. to valid regulations, but minimum once a year by an *Enterprise Of Competence*. Due to use- and environment, it may be necessary to increase intervals.  
This will occur especially due to frequent use, wear, corrosion and increased possibility of fault.  
Inspection has to be documented in the certificate (control book).
- Dirty lifting equipment and/or exposed to salt or chemicals during storage and operation, may be subjected to cleaning prior to inspection.

#### **4.3 EXTRAORDINARY INSPECTION**

- In case of injuries or special events that may affect the lifting capacity, an extraordinary control has to be carried out by an *Enterprise Of Competence*.  
The extent of this control is due to the type of the injury, event or repair, and has to be determined individually.

## **5. USE**

### **Basics**

Clamp H-Beam 80-180 is to be used for hanging elements on H-beam with flange width 80-180 mm, flange thickness max. 35 mm and thickness of web max 16 mm.

Clamp H-Beam 80-180 must not have any oblique drag load put on them. These types are made for vertical drag and cannot deviate more than 3° from the vertical measured from the angle of the beam.

### **Preparations prior to assembling**

- After unpacking and visual inspection of Clamp H-Beam 80-180, remove all thread protectors.
- Check cleanliness and check for any visual damages.
- Check that lifting beam is fit for use of the purpose (respectively type and SWL).

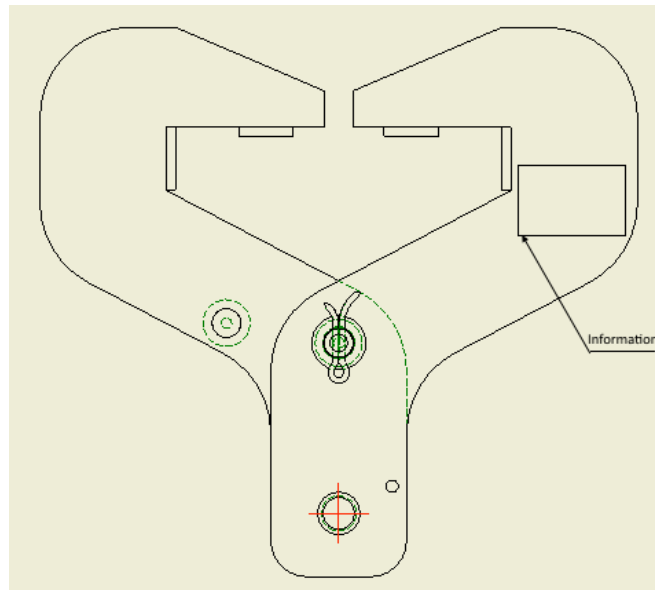

**DWG. 2 Clamp H-Beam 80-180 - Marking**

### Mounting Clamp H-Beam 80-180 and load

- Mount suitable and certified lifting equipment on to Clamp H-Beam 80-180 hole for transport
- Lift and transport to the load, place in a suitable position for assembling

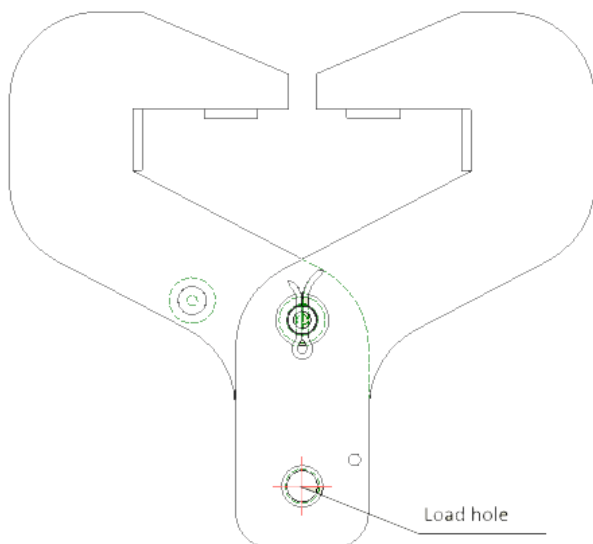

### DWG. 3 Clamp H-Beam 80-180 and load

- Attach the load to the right lugs of Clamp H-Beam 80-180
- Make a visual inspection of the assembly
- Lift and hanging the load

### Put down load

- Put down the load on the prepared determined area
- Disconnect the load from the Clamp H-Beam 80-180
- Lift and transport the Clamp H-Beam 80-180 to the accumulation point

**TABLE 1 - List of parts**

ITEM	QUANTITY	PART NUMBER	DESCRIPTION	MATERIAL	MASS
1	1	WT-80-180	Clamp H-Beam 80-180	S355J2	4,8 kg